

FONIX®

ANSI '03 Workbook

An instructional workbook designed to help hearing health students become familiar with the ins and outs of testing hearing aids according to the ANSI S3.22 standard.

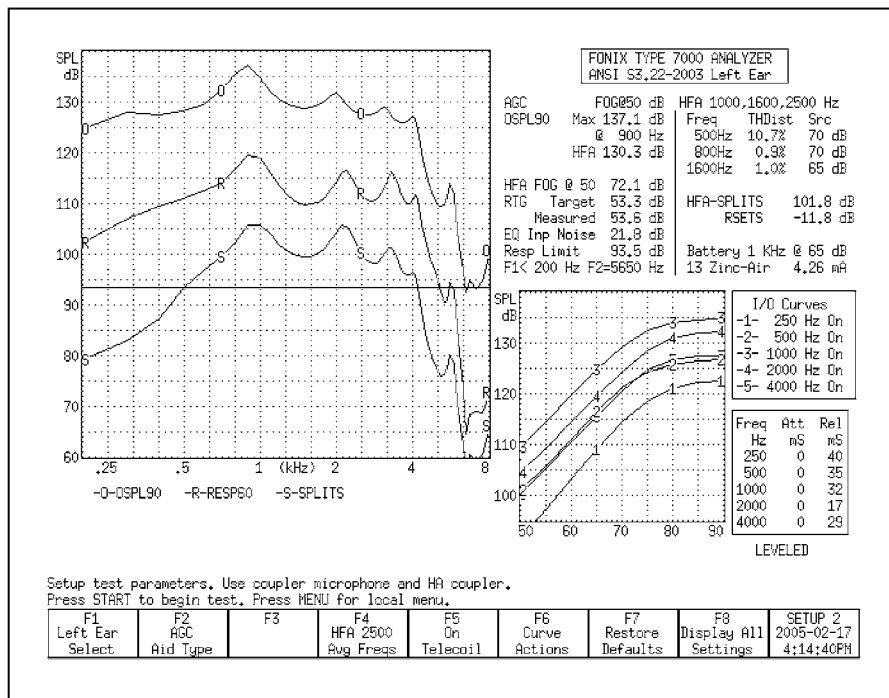

FRYE ELECTRONICS, INC.
 P.O. Box 23391 • Tigard, OR 97281-3391 • USA
 (503) 620-2722 • (800) 547-8209
 Fax: (503) 639-0128
 www.frye.com • e-mail: sales@frye.com

Copyright © 2005 Frye Electronics, Inc. All rights reserved.

TABLE OF CONTENTS

Introduction.....	1
The Testing System	3
Hearing Aid Types	5
Linear Hearing Aid	5
Automatic Gain Control (AGC) Hearing Aid {3.16}.....	6
Directional Hearing Aid {3.19}	7
Special Purpose Hearing Aid {3.4}	7
Basic Definitions.....	8
Preparing to Test	11
Setting the Trimmers or Programming	11
Choosing the Correct Coupler	11
Preliminary Practice	12
Leveling the Test Equipment.....	12
Equivalent Substitution Method (single-microphone systems only)	12
Leveling Check	14
Averaged Measurements.....	15
High Frequency Average (HFA)	15
Special Purpose Average (SPA).....	16
Practice with ANSI Test Procedures	17
Output Sound Pressure Level (OSPL-90).....	17
HFA (or SPA) Full-On Gain.....	18
Reference Test Gain	19
Reference Test Setting of the Gain Control	20
Frequency Response Curve.....	23
Frequency Limits	23
Total Harmonic Distortion {6.11}	29
The 12-dB Rule	30
Equivalent Input Noise {6. 12}	32
Battery Current Drain {6.13}	33
Telecoil Sensitivity {6.14}.....	35
SPLITS Curve {6.14.1}	35
HFA- or SPA-SPLITS {6.14.2}	36
Relative Simulated Equivalent Telephone Sensitivity {6.14.3}	37
Input-Output (1/0) Characteristic(AGC instruments only) {6.15.1}	38
Attack & Release Times (AGC instruments only) {6.15.2}.....	40
Tests for Linear Instruments	41
Tests for AGC Instruments	42
Summary of Tolerances.....	44
Answers	45

EXERCISES

- Check the analyzer specs: 4
- Calibrate the analyzer microphone(s): 4
- Choose linear instruments for testing:..... 5
- Choose AGC instruments for testing: 6
- Choose a special purpose hearing aid for testing: 7
- Set up for leveling: 13
- Run a leveling check: 14
- Brush up on averaging 15
- Calculate a high-frequency average (HFA): 15
- Calculate a special purpose average (SPA): 16
- Measure the OSPL-90 data 17
- Measure the HFA (or SPA) full-on gain: 18
- Calculate the reference test gain: 19
- Calculate the target HFA (or SPA) output level for the reference-test position: 20
- Set the gain control to the reference-test-gain position: 21
- Calculate the frequency range: 24
- Determine the required graph limits: 25
- Determine the frequency response tolerance limits:..... 26
- Make a “tolerance template:” {6.10.2}..... 26
- Check whether the frequency response curve meets specs 27
- Determine the %THD test frequencies: 29
- Use the 12-dB rule:..... 30
- Measure the %THD: 31
- Determine the EIN level: 32
- Determine the maximum permissible battery current:..... 34
- Measure the battery current: 34
- Measure the SPLITS curve: 35
- Determine the HFA-SPLITS: 36
- Determine the RSETS value:..... 37
- Measure the I/O characteristic: 39
- Find the AGC knee point:..... 40
- Run a “complete” ANSI test sequence:..... 43
- Run a “complete” ANSI test sequence:..... 43

INTRODUCTION

The American National Standard Specification of Hearing Aid Characteristics, ANSI S3.22, specifies the electroacoustic tests a manufacturer must perform and publish for each hearing aid before the instrument is shipped. The standard also specifies the allowed tolerances for shipped instruments, so that you, the clinician or dispenser, can perform the same tests to verify the performance of an instrument against specifications. This instructional workbook is designed to help students and workers become familiar with the “ins and outs” of testing hearing aids according to the S3.22 standard.

Testing the electroacoustic performance of hearing instruments serves two general purposes: 1] To verify that an instrument is functioning *properly*; that is, according to the *manufacturer’s specifications*; and 2] To verify that an instrument is functioning *appropriately*; that is, according to the *auditory needs of the wearer*. The S3.22 standard, and this workbook, address only the first of those purposes. The tests described focus solely on determining whether the performance of a hearing aid is in agreement with factory specifications.

The instructions and exercises in this workbook are based on the assumption that the student already knows how to operate the hearing-aid analyzer—i.e., how to attach a hearing aid to the appropriate coupler, how to adjust the signal level and frequency, how to read output levels and distortion at individual frequencies, and how to run a pure tone frequency-response test. If the analyzer has an automatic ANSI test sequence, that automatic sequence should not be used with this workbook; all tests should be run individually. Answers to questions in the exercises are printed at the back of the workbook. A superscripted number following a question notes where the corresponding answer falls in the list of answers.

The reference test for this workbook is the ANSI S3.22-2003 publication.* Citations {given in curly brackets} refer to section numbers within that publication. The reader is encouraged to obtain a copy for use with this workbook and for future reference. A second important reference source is the operator’s manual of your analyzer.

*This standard is available from the Standards Secretariat of the Acoustical Society of America, 335 East 45th Street, New York, New York 10017-3483, <http://asa.aip.org/>

THE TESTING SYSTEM

The testing system includes both the test equipment (the hearing-aid analyzer) and the test environment (the room in which testing is done). Specific requirements for both the test equipment and the test environment are given in Sections {4.1-5.1} of the standard. These requirements are paraphrased below:

Sound source:	Accurate within ± 1.5 dB over the range 200-2000 Hz; within ± 2.5 dB over range 2000-5000 Hz.
Frequency accuracy:	Accurate within $\pm 2\%$; printed within $\pm 5\%$
Coupler types:	HA-1 and HA-2 (<u>see ANSI S3.7</u>)
Coupler microphone:	Flat within ± 1 dB over the range 200-5000 Hz; Calibrated within ± 1 dB at any stated frequency
between 250 and 1000 Hz.	Within ± 1 dB of true rms for noise signals
Averaging time:	≥ 0.5 s, for internal noise measurements
Battery current (I):	Accurate within $\pm 5\%$; DC voltage drop ≤ 50 mV; AC impedance ≤ 1 ohm over the range 20-5000 Hz.
Ambient temperature:	$23^{\circ}\text{C} \pm 5^{\circ}$ ($73^{\circ}\text{F} \pm 9^{\circ}$)
Ambient relative humidity:	0% to 80%
Ambient atmospheric pressure:	760 mm of Hg (+35, -150) or 101.3 kPa (+5, -10)

Tolerances {6.16}:

All the tolerances given in S3.22 assume "perfectly accurate measurement equipment." To be certain that a hearing aid meets or does not meet its performance specs, the tolerances of the measurement equipment must be added to or subtracted from the S3.22 tolerances, as appropriate. (Refer to Section {6.16} for further explanation.)

Exercise: Check the analyzer specs:

Check the specifications of your test equipment and the ambient conditions of your test environment. Does the testing system meet all ANSI requirements? Where does it fall short? How can these shortcomings affect measurements?¹

Notes:

Exercise: Calibrate the analyzer microphone(s):

If possible, have your instructor, technician, or teaching assistant help you check, and if necessary, adjust the calibration of the microphone(s) used with your analyzer.

Notes:

HEARING AID TYPES

LINEAR HEARING AID

A true linear hearing aid is a hypothetical device whose gain and frequency response remain the same, regardless of the input signal. Actually, no linear hearing aid exists because all hearing aids will saturate once the input level is high enough and often at a level within the range encountered by hearing-aid users. Saturation causes substantial changes in gain, frequency response, and distortion, making performance substantially non-linear. However, for the purpose of distinguishing hearing-aid types for ANSI testing, the term “linear” is commonly used to describe an instrument whose gain and frequency response remain constant when the instrument is not saturated and whose maximum output is controlled by peak clipping.

Exercise: ***Choose linear instruments for testing:***

Check published specification sheets from hearing aids in your dispensary stock and list the model numbers for several linear (peak-clipping) instruments. These instruments should not be directional hearing aids. Be sure that at least one is a high-gain instrument, at least one is a moderate-gain instrument, and at least one is a mild-gain instrument. And, at least one should have a telecoil (unless you will be including an AGC instrument with a telecoil on the list in the next exercise). You will use the listed instruments for practice in later exercises.

List:

AUTOMATIC GAIN CONTROL (AGC) HEARING AID {3.16}

An AGC hearing aid is an instrument whose gain is controlled automatically as a function of the level of the signal being amplified. This automatic control of gain is usually designed to reduce the range of output levels as compared to the range of input levels. Such AGC action is called “compression.” In general, there are two forms of compression:

- **Input compression** (dynamic-range compression)—The extent of gain reduction is determined by the level of the input to the hearing aid. This form of compression is used to match the dynamic range of a hearing aid to the reduced auditory dynamic range found in the recruiting ear.
- **Output compression** (output-limiting compression)—The extent of gain reduction is determined by the level of the output of the hearing aid. This form of compression is used to limit the maximum output of a hearing aid while avoiding saturation distortion.

Exercise: Choose AGC instruments for testing:

Check published specification sheets from instruments in your dispensary stock and list the model numbers for several AGC instruments. These instruments should not be directional hearing aids. Be sure that at least one has input (dynamic-range) compression and at least one output has (output-limiting) compression. And, at least one should have a telecoil, unless you already have a linear instrument with a telecoil on the list from the last exercise.

List:

DIRECTIONAL HEARING AID {3.19}

A directional hearing aid is an instrument whose microphone output changes as a function of the direction from which sound waves arrive at the input. An anechoic environment, one in which sound vibrations are all but eliminated, is required for testing directional hearing aids according to the S3.22 standard. Consequently, directional hearing aids will not be used with this workbook.

SPECIAL PURPOSE HEARING AID {3.4}

A special purpose hearing aid is an instrument whose effective bandwidth lies substantially outside the usual amplification range; specifically, where the full-on gain at any of the “HFA” frequencies (1000, 1600, and 2500 Hz) is more than 15 dB lower than the maximum full-on gain at any frequency. Examples are high-frequency- or low-frequency-emphasis instruments.

Exercise: ***Choose a special purpose hearing aid for testing:***
Check the published manufacturer specifications for the aids you listed in the previous two exercises. Make sure that a least one aid uses special purpose frequencies rather than the standard HFA frequencies.

BASIC DEFINITIONS

Definitions of terms are found in Sections {3} and {6} of the S3.22 publication. Additional definitions are given below for the purposes of instruction. Later in the workbook, the meaning of these definitions are enhanced by further explanations and exercises.

ACOUSTIC GAIN {3.7}—Acoustic gain (also called, simply, gain) is the difference, in dB, between the output level and the input level.

ATTACK TIME {6.15.2}—The attack time of an AGC instrument is the time it takes for the output to settle to the steady-state level after the input is abruptly changed from 55 dB to 90 dB.

EQUIVALENT INPUT NOISE LEVEL {6.12}—The equivalent input noise level (EIN) is the output level of the noise generated by the hearing aid minus the gain of the aid.

FREQUENCY RESPONSE—In general, a frequency response is a set of output levels, generated as a function of frequency, for a fixed input level. Sometimes, frequency response is expressed in terms of gain by subtracting the input level from each output level.

FREQUENCY RESPONSE CURVE {6.8}—In general, a frequency response curve is a graphical representation of the frequency response of an instrument. However, in S3.22, the term “frequency response curve” is reserved for the following specific test conditions: the input level is 60 dB SPL, and the gain control is at the reference-test position.

FULL-ON POSITION—Full-on means the gain control of the hearing aid is at its maximum position.

GAIN CONTROL {3.8}—Gain control is the technically correct term for what is commonly called “volume control.”

HARMONIC—A harmonic is an integral multiple of a given frequency. For example, the first harmonic of a frequency is the frequency itself; the second harmonic of a frequency is twice the frequency; the third harmonic is three times the frequency; etc.

HARMONIC DISTORTION {6.11}—An instrument exhibits harmonic distortion when the instrument produces harmonics in the output signal that are not present in the input signal. The test for percent total harmonic distortion (%THD) measures the power produced in the output of a hearing aid at frequencies equal to the second and higher harmonics of the input signal as compared to the power produced at the actual frequency of the input signal. The precise description of the %THD is given in Section {6.11} of the standard.

HIGH-FREQUENCY AVERAGE (HFA) {3.2}—The HFA is the average of the decibel values at 1000, 1600, and 2500 Hz.

HIGH-FREQUENCY AVERAGE SPLITS (HFA-SPLITS) {3.22}—The HFA-SPLITS value is the average of the decibel levels at 1000, 1600, and 2500 Hz taken from a SPLITS curve with the hearing-aid gain control at the reference-test position.

INPUT-OUTPUT (I/O) CHARACTERISTIC {6.15.1}—An input-output characteristic is a set of output levels, generated as a function of input level, for a fixed input frequency (or frequency band). In S3.22, I/O testing is done only on AGC instruments.

INPUT SOUND PRESSURE LEVEL {3.5}—The input sound pressure level (also called input level) is the SPL at the inlet of the hearing aid microphone. This level is determined by the leveling or controlling microphone of the analyzer.*

OUTPUT SOUND PRESSURE LEVEL—The output sound pressure level (also called output level) is the SPL measured by the coupler microphone.

OUTPUT SOUND PRESSURE LEVEL FOR 90 dB INPUT SPL (OSPL90) {3.9}—the OSPL90 is the output level of a hearing aid when the input level is 90 dB SPL and the gain control is full-on.

REFERENCE-TEST GAIN {3.13}—The reference-test gain is the gain of the hearing aid when the gain control is set so that a 60 dB SPL input signal yields an HFA (or SPA) value that is 17 dB below the HFA (or SPA) OSPL90 value. Exceptions: If the actual HFA (or SPA) output level for the full-on position is already lower than 17 dB below the OSPL90 level, then the full-on gain is considered the reference-test gain.

*The above definition of “input sound pressure level” applies only to non-directional hearing aids. Testing directional hearing aids according to S3.22 requires special test conditions not available in commercial hearing aid analyzers.

REFERENCE-TEST SETTING (RTS) {3.12}—The reference-test setting is the position of the gain control necessary to yield the reference-test gain.

RELATIVE SIMULATED EQUIVALENT TELEPHONE SENSITIVITY (RSETS) {3.23}—Difference in decibels between the HFA-SPLITS (or SPA-SPLITS) and HFA (or SPA) in the normal operating mode with the gain control in the reference-test position and an input signal of 60 dB.

RELEASE TIME {6.15.2}—The release time of an AGC instrument is the time it takes for the output to settle to the steady-state level after a 90 dB SPL input signal abruptly drops to 55 dB SPL.

RMS LEVEL—The rms level is the overall, long-term power level of a signal.

SOUND PRESSURE LEVEL (SPL)—The designation decibel means that the value given is a comparison between a particular sound pressure and a reference sound pressure. The reference sound pressure for SPL is 20 microPascals (mPa) {3.1}. (This sound pressure is close to the minimum audible pressure at 1000 Hz.) Saying “dB SPL” is equivalent to saying “dB re 20 mPa.” The formula for determining dB SPL is

$$\text{dB SPL} = 20 \log_{10}(\text{sound pressure} \div 20 \mu\text{Pa})$$

SPECIAL PURPOSE AVERAGE (SPA) — The “SPA” is the average of decibel values at three frequencies specified by a manufacturer in lieu of the HFA frequencies, according to the rules given in Section {3.3} of the standard.

SPECIAL PURPOSE AVERAGE-SPLITS (SPA-SPLITS)—The SPA-SPLITS value is the average of the decibel levels at three manufacturer-specified frequencies taken from a SPLITS curve with the hearing-aid gain control at the reference-test position.

SPLITS {3.21}—SPLITS is an abbreviation for SPL in an inductive telephone simulator. A coupler curve is run with the hearing aid in telecoil mode with the gain control at the reference-test position. The input is a magnetic field generated by a Telephone Magnetic Field Simulator (TMFS).

STEADY-STATE LEVEL—The steady-state level is the final level reached and maintained after a transition between two levels.

TELEPHONE MAGNETIC-FIELD SIMULATOR (TMFS) {3.24}—The TMFS is a device used to produce a magnetic field that is consistent in both level and geometric shape. According to the standard, the current shall be equal to 6 milliamperes divided by the number of coil turns.

PREPARING TO TEST

SETTING THE TRIMMERS OR PROGRAMMING on the hearing aid in preparation for testing

The basic settings of controls are given in Section {5.2.5}. In general, set all trimmers or programming to give the widest possible frequency response range, the maximum gain, and the maximum output. If it is not possible to achieve both the maximum output and the maximum gain, set the aid for the maximum output. An exception is an AGC instrument having compression controls {3.17}. Set the controls as indicated by the manufacturer. The manufacturer may designate the settings with a clear physical mark, as the end of the control rotation, or with programmable parameter values. Where possible, these controls will be with the compression controls set to have minimum effect for all measurements except the input/output, and attack and release measurements. For those measurements, the compression controls will be set to have maximum effect.

CHOOSING THE CORRECT COUPLER

Follow the instructions in your analyzer operator's manual for attaching hearing aids to the various coupler configurations.

- ITE and Canal instruments: Use the HA-1, direct access coupler. A vent must be sealed at the outer opening (at the faceplate).
- BTE instruments: Use the HA-2 coupler/earmold simulator, with the tubal extension.
- Body instruments: Use the HA-2 coupler/earmold simulator, without the tubal extension.

PRELIMINARY PRACTICE

LEVELING THE TEST EQUIPMENT

“Leveling” is the procedure that adjusts the electrical drive to the loudspeaker so that each frequency is presented at a predetermined level during testing. With analyzers that use separate microphones for leveling and for measuring, leveling is done automatically, at the time of testing {4.2}. With analyzers that use the same microphone both for leveling and for measuring, leveling is done before testing {Annex A}.

In any case, leveling must account for *all* items present in the test chamber at the time of testing. In other words, the complete hearing aid/coupler/microphone apparatus (or equivalent) must be in place during leveling. With a single-microphone system, the “Equivalent Substitution Method” is used (see below), and leveling must be redone whenever a change is made that could affect the acoustics of the measuring system, such as when changing the type of hearing aid from ITE to BTE.

EQUIVALENT SUBSTITUTION METHOD (single-microphone systems only)

Single-microphone analyzers must use the Equivalent Substitution Method for ANSI leveling (described fully in {Annex A} of the standard). For the Equivalent Substitution Method, you must have a “dummy microphone” (or microphone substitute) that has the same physical dimensions as the actual microphone. During leveling, the dummy microphone takes the place of the measuring microphone inside the coupler; the measuring microphone is placed near $(5\text{mm} \pm 3)$ the opening of the hearing aid microphone. During testing, the positions of the dummy microphone and the measuring microphone are reversed.

Exercise: Set up for leveling:

Using a BTE hearing aid, practice setting up for leveling. Have the instructor verify that you have the correct setup for leveling, as illustrated in the figure (A) below.

(If you have single-microphone system, now reverse the positions of the dummy microphone and the measuring microphone, as illustrated in the figure (B) below. Again, have the instructor verify that you now have the correct setup for testing.)

Repeat the exercise using an ITE hearing aid.

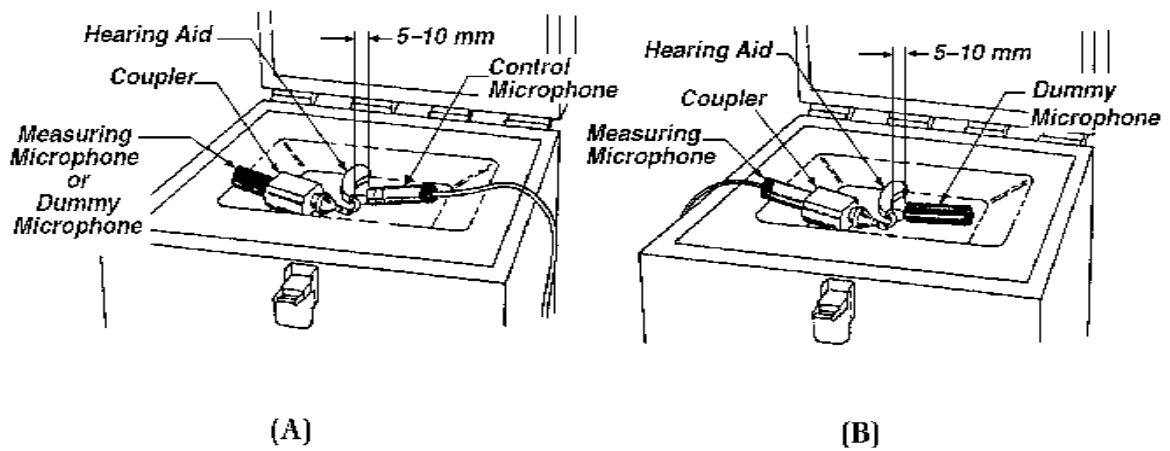

LEVELING CHECK

It's a good idea to check the accuracy of your leveling/testing system, from time-to-time, by running a leveled frequency response test without a hearing aid and coupler present. The result is the frequency response of the testing system, which should show the output level to be the same as the input level at every frequency within ± 1.5 dB between 200 and 20000 Hz and within ± 2.5 dB between 2000 and 5000 Hz.

Exercise: **Run a leveling check:**

Instructions:

1] Place the measuring microphone at the reference position in the sound chamber, as illustrated in the figure (A) below. Do not use a hearing aid or a coupler. With dual-microphone systems, place the leveling microphone facing, and within 5 ± 3 mm of, the measuring microphone, as illustrated in the figure (B) below.

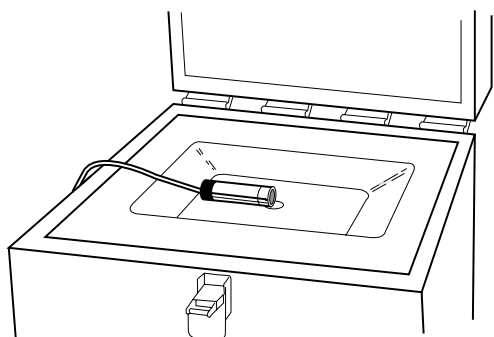

(A)

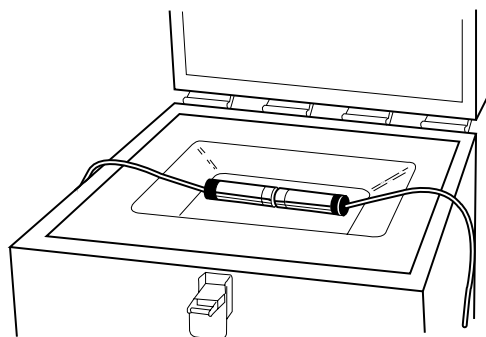

(B)

2] With a single-microphone system, level the system at this time. Otherwise, proceed to the next step.

3] Using a 90 dB SPL signal, run a pure tone frequency response in this configuration. The resulting measurement is the frequency response of the measuring system itself. The measured levels at each frequency should be very nearly the same, 90 dB SPL. (An example is shown below.) Does your measured frequency response conform to the ANSI tolerances {4.4}?² (This check assumes that the measuring microphone is completely accurate.)

AVERAGED MEASUREMENTS

Several of the tests in the S3.22 sequence require taking the average of readings at three frequencies.

Exercise: ***Brush up on averaging***

Calculate the average of these three numbers: 49, 37, and 43.

1. *Find the sum of the three numbers.*

49

37

43

*Sum.*³

2. *Divide the sum by three.*

Sum _____ \div 3 = _____⁴

▪ HIGH FREQUENCY AVERAGE (HFA)

The High-Frequency Average (HFA) is the average of the decibel values at 1000, 1600, and 2500 Hz. Those three frequencies were chosen by ANSI because most hearing aids produce “usable” output at those frequencies. An HFA reading, therefore, gives a single number that represents the overall performance of an instrument for the test conditions in question.

Exercise: ***Calculate a high-frequency average (HFA):***

Calculate the HFA of the following curve:

Instructions:

1] *Find the decibel values of output for the frequencies 1000, 1600, and 2500 Hz.*

2] *Calculate the average of those values.*⁵

Notes:

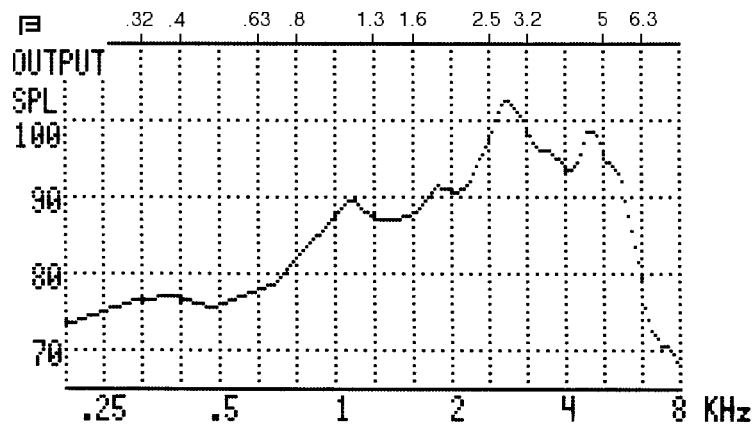

▪ **SPECIAL PURPOSE AVERAGE (SPA)**

When a hearing aid is not designed to produce “usable” output levels at all three HFA frequencies, a manufacturer may designate that instrument a “special purpose” hearing aid. In such cases, the manufacturer may specify three alternate frequencies to be considered for averaged measurements. The conditions required for the “special purpose” designation are given in Section {3.3} of the standard.

Exercise: Calculate a special purpose average (SPA):

The manufacturer of the hearing aid whose frequency response appears in the graph below, has specified the following frequencies as SPA frequencies: 1600, 2500, and 4000 Hz.

What is the SPA output?⁶

If the input level used to generate the response curve was 60 dB SPL, what is the SPA GAIN? (Hint: Subtract the input level from the SPA output level to get the gain.)

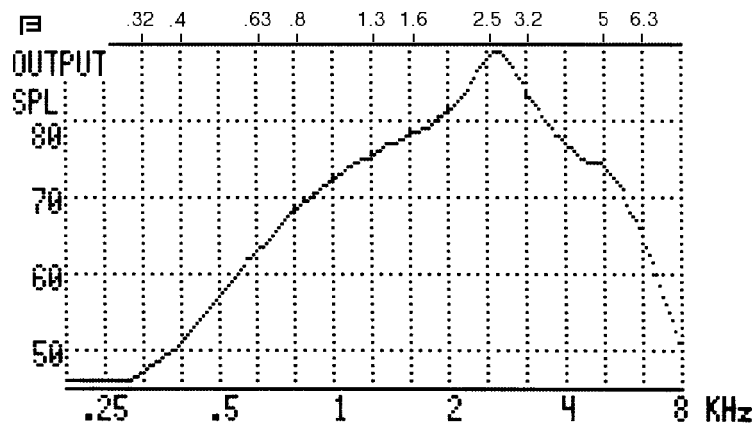

PRACTICE WITH ANSI TEST PROCEDURES

OUTPUT SOUND PRESSURE LEVEL (OSPL-90)

The OSPL90 measurements use an input level of 90 dB SPL with the hearing-aid gain control in the full-on position. ANSI chose 90 dB SPL with the gain control full on because most—although, not all—hearing aids will be saturated under those conditions. Therefore, OSPL90 readings are estimates of maximum possible output. S3.22 requires an OSPL90 curve {6.2}, an OSPL90 maximum sound pressure level reading {6.2}, and an OSPL90 HFA (or SPA) reading {6.3}. The last two readings can be derived from the OSPL90 curve.

Tolerances

The maximum OSPL90 reading has to be no more than 3 dB higher than the manufacturer's specification {6.2}.

The HFA (or SPA) OSPL90 has to be within ± 4 dB of the manufacturer's specification {6.3}.

No other OSPL90 tolerances are given.

Exercise: *Measure the OSPL-90 data.*

Instructions:

- 1] Set the trim controls and gain control of one of the linear instruments on you list for the broadest and most powerful response.*
- 2] Level the analyzer (if necessary).*
- 3] Set the input level for 90 dB SPL.*
- 4] Run a pure tone frequency response.*

5] Read directly from the graph (not from printed data calculated by the analyzer) to find the maximum sound pressure level developed at any frequency. At what frequency does this occur? (Optional: If your analyzer calculates these readings for you, check your own readings by comparing them to the calculated readings.) Is the result within specs?

6] Again, by reading your own graph, calculate the HFA (or SPA) OSPL90 {6.3}. (Optional: If your analyzer calculates this reading for you, check your own reading by comparing it to the calculated reading.) Is the result within specs?

Notes:

HFA (OR SPA) FULL-ON GAIN

Although many manufacturers publish complete full-on gain curves in their specs, ANSI S3.22 requires only that the full-on gain be stated as a high frequency (or special purpose) average {6.5}. To arrive at the HFA (or SPA) full-on gain reading, measure and average the full-on output level at the HFA (or SPA) frequencies, and then subtract the input level of 50 dB SPL.

Tolerance:

The HFA (or SPA) full-on gain has to be within ± 5 dB of the manufacturer's spec {6.5}.

Exercise: Measure the HFA (or SPA) full-on gain:

Instructions:

1] Using one frequency at a time (do not run a response curve), with the input level set to 50 dB SPL, measure and record the output levels for each of the HFA (or SPA) frequencies.

2] Calculate the average of the three output levels.

3] Subtract the input level. The result is the HFA (or SPA) full-on gain.

Notes:

REFERENCE TEST GAIN

The rationale for reference-test gain (given in Section {3.12}) can be paraphrased as follows: The average level of normal, conversational speech in quiet is 65 dB SPL. Typically, speech levels vary over time by +12 dB and -18 dB relative to the average level. Therefore, the typical maximum level of conversational speech in quiet is 77 dB SPL. For testing hearing aids under simulated normal-use conditions, S3.22 prescribes a gain setting such that the range of amplified speech levels would fall at or below the hearing-aid saturation level. Because the typical maximum speech (input) level is 77 dB SPL, the reference-test gain is the hearing aid saturation level (HFA- or SPA-OSPL90 level) minus 77 dB.

Tolerance: None.

According to S3.22 {6.7}, the reference test gain is “stated for information purposes only.” There is no required performance tolerance to be met for this measure.

Exercise: Calculate the reference test gain:

For the hearing aid whose OSPL90 graph appears below, calculate the reference test gain.

Instructions:

- 1] Read and record the OSPL90 output levels at the HFA frequencies (1000, 1600, and 2500 Hz).*
- 2] Calculate the average value.*
- 3] Subtract 77 dB. The result is the reference test gain.⁸*

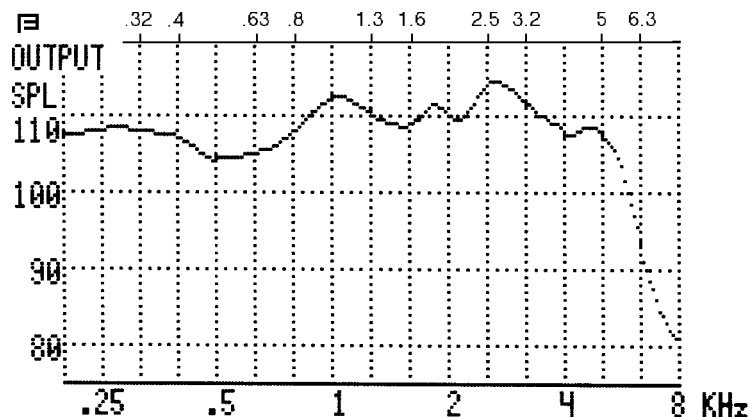

REFERENCE TEST SETTING OF THE GAIN CONTROL

To set the gain control to the reference-test position, you must first determine a target HFA (or SPA) output level. The input level used to set the gain control to the reference-test position is 60 dB SPL.* In general, the output level is the input level plus the gain. Therefore, the target HFA (or SPA) output level would be 60 dB SPL plus the reference-test gain. (This level is also equal to the HFA or SPA OSPL90 level minus 17 dB.)

Tolerance {3.12}

A tolerance of ± 1.5 dB is allowed for setting gain control to the reference-test position. In other words, the measured HFA (or SPA) output for a 60-dB SPL input, after setting the gain control to the reference-test position, may be as much as 1.5 dB higher or lower than the calculated target level.

Exercise: **Calculate the target HFA (or SPA) output level for the reference-test position:**

Do examples (a) and (b) below.

Example (a): Derive the target reference-test output level from the calculated reference-test gain. The calculated reference-test gain for a hearing aid is 39.5 dB. What is the target HFA (or SPA) output level?⁸

Example (b): Derive the target reference-test output level from the OSPL90 data. The OSPL90 curve for a hearing aid is given on the following page. What is the target HFA output level?

Instructions:

1] Read and record the output levels at the HFA frequencies (1000, 1600, and 2500 Hz).

2] Calculate the average value.

3] Subtract 17 dB.⁹

* The reason for using a 60-dB-SPL input level, instead of 65-dB-SPL, is that at the time the S3.22 standard was originally written, most of the available frequency response test equipment was calibrated at integral multiples of 10 dB. Consequently, the available choice was to use either 60 dB SPL or 70 dB SPL.

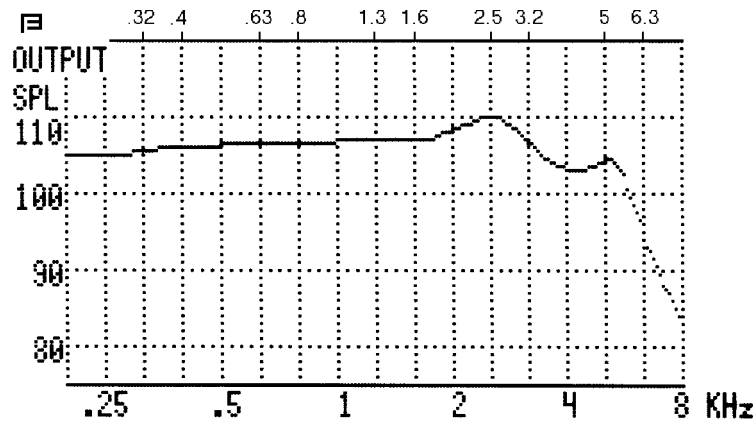

Exercise: **Set the gain control to the reference-test-gain position:**
This could be the trickiest procedure in the entire S3.22 sequence. But if you proceed carefully, it's easy.

Instructions:

1] *Using one of the linear hearing aids on your list (not a special purpose aid, and preferably a high-output device), calculate the target HFA output level (run an OSPL90 curve; find the HFA-OSPL90 level; subtract 17 dB). What is the acceptable range of achieved output levels, considering the permitted ± 1.5 dB tolerance?*

2] *Change the input level from 90 to 60 dB SPL, but do not yet change the gain control position (leave it at the full-on position).*

3] *Measuring the output level at one frequency at a time (1000, 1600, and 2500 Hz), determine the HFA output for a 60-dB SPL input.*

4] *Subtract the target HFA output of step [1] from the measured HFA output of step [3]. This is the number of dB you must change the HFA gain by turning down the gain control.**

Measured HFA – target HFA = number of dB lower gain control should be.

* If the number of dB indicated is less than one, then the gain control is already at an acceptable position. For this exercise, use a hearing aid that requires you turn the gain control down.

5] With the input signal at any one of the HFA frequencies (still at 60 dB SPL), monitor the output level while turning the gain control down. Stop when the output has come down the needed decibel amount from the full-on level.

6] In many cases, the position of the gain control achieved in step [5] is already within the acceptable range of the reference-test position. But you must verify this by measuring the HFA output. Measure the output at each of the HFA frequencies, and then calculate the average.

Notes:

7] Is the HFA output within the acceptable range of the target (± 1.5 dB)? If not, subtract the target HFA output from the measured HFA output of step [6]. This is the new number of dB you must change the HFA gain by turning down the gain control.

8] Repeat steps [5], [6], and [7] until an acceptable HFA output level is reached.

FREQUENCY RESPONSE CURVE

The frequency response curve for linear instruments is measured with the gain control within ± 1.5 dB of the reference-test position, using an input level of 60 dB SPL.

Tolerances {6.10.1}:

The low-band portion of the frequency response curve (<2 kHz) must fall within ± 4 dB of the specified curve.

The high-band portion of the frequency response curve (>2 kHz) must fall within ± 6 dB of the specified curve.

Note: Because there is not a tolerance requirement for the reference-test gain, there is also not a tolerance requirement for the overall level of the frequency response curve. Consequently, before deciding whether a measured frequency response curve meets specs, the examiner may shift the measured curve up or down along the dB scale as much as is necessary to align the measured curve to fit the tolerance ranges of the specified curve. The examiner may also shift the measured curve horizontally along the frequency scale, but only so much as to cause a ten-percent change in frequency. For example, the measured curve may be shifted so as to align the 1000 Hz point on the measured curve with a point on the specified curve as low as 900 Hz or as high as 1100 Hz {6.10.2}

FREQUENCY LIMITS

There are three different ways that S3.22 sets lower and upper frequency limits on the frequency response curve. These are stated frequency range, required graph limits, and frequency response tolerance limits. Each set of limits is a distinct variation of the frequency values known as f_1 and f_2 .

- **Stated Frequency range (f_1 and f_2) {6.9}:** The limits of the stated frequency range are the lowest and highest frequencies at which the frequency response curve crosses the level that is 20 dB below the HFA (or SPA) level of the curve. The low-frequency limit is called f_1 , and the high frequency limit is call f_2 . An example follows.

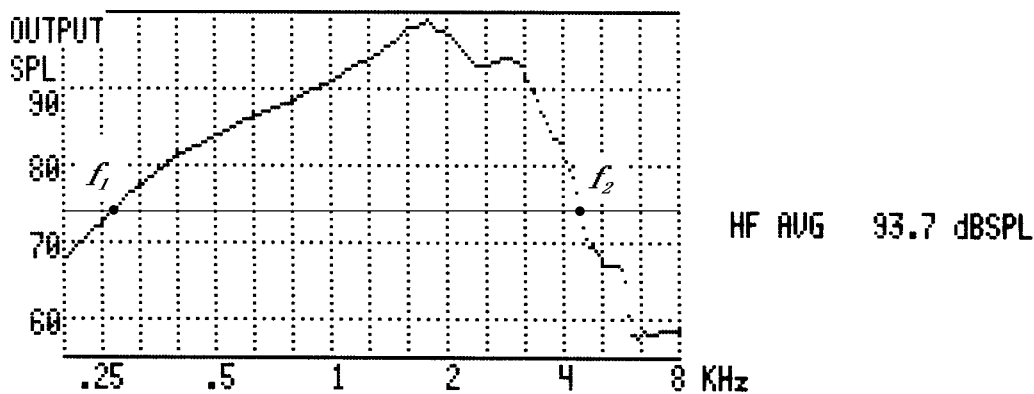

Tolerance: None

The frequency range is published “for information purposes only.” There is no required performance tolerance to be met for this measure. However, f_1 and f_2 are used for other purposes discussed later.

Exercise: Calculate the frequency range:

Examples of specified frequency response curves for two hearing aids are shown below. Find “ f_1 ” and “ f_2 ” for each.

Instructions (Do the following for each of the two examples):

First, make photocopies of the example curves that follow to use in the exercises. Then, using the photocopies, follow the steps below for each hearing aid.

1] Determine the HFA level of the frequency response curve.¹⁰

2] Subtract 20 dB. Call this level the “response limit” level.¹¹

3] Draw a horizontal line across the frequency response graph at the response limit level.

4] Read, record, and mark on the graph the lowest and highest frequencies at which the frequency response curve crosses the response limit. These frequencies are f_1 and f_2 , respectively.¹²

Notes:

Specified Curves

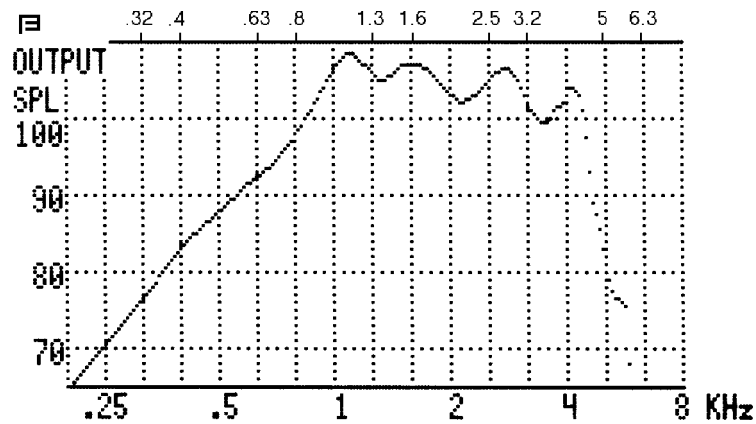
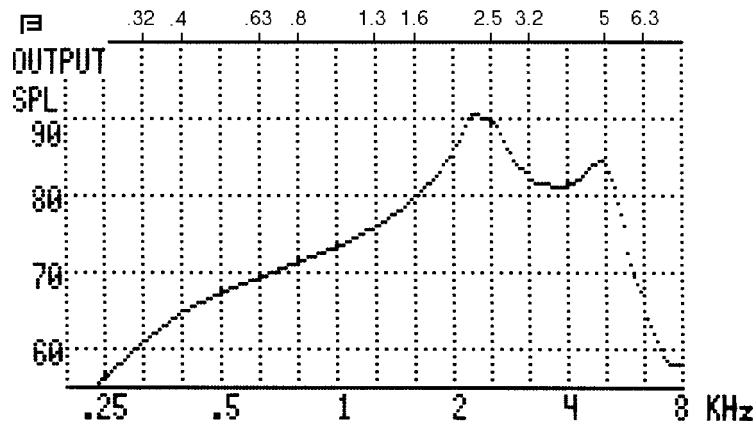

- **Required graph limits {6.8}**: The absolute lowest frequency for which the manufacturer is required to plot the frequency response curve is 200 Hz or f_1 , whichever is the higher of the two. The absolute highest frequency for which the manufacturer is required to plot the frequency response curve is 5000 Hz or f_2 , whichever is the lower of the two.

Exercise: *Determine the required graph limits:*
 For each of the two examples in the previous exercise, what are the required frequency limits for which the manufacturer has to publish the frequency response? (Use the rules given just above.) 13

- **Frequency response tolerance limits {6.10.1}**: For the purpose of tolerance requirements, the frequency response curve is broken up into two bands, low and high. The low and high bands are divided at 2000 Hz. The outer limits of the two bands are as follows:

Low-band: The lowest frequency for which the frequency response curve must meet the tolerance requirements is 1.25 times f_1 , or 200 Hz, whichever is higher.

High-band: The highest frequency for which the frequency response curve must meet the tolerance requirements is .8 times f_2 , or 4000 Hz, whichever is lower.

Exercise: Determine the frequency response tolerance limits:

Using the response curves from the earlier example, determine the outer frequency limits of the low and high tolerance bands for each of the two hearing aids.

Instructions: (Do the following on the photocopies you made of the two specified frequency responses. These will be used for subsequent exercises, as well.)

1] Draw a bold vertical line through the entire graph at 2000 Hz. This marks the border between the low and high tolerance bands.

2] Determine the lower limit of the low band (1.25 times f_1 , or 200 Hz, whichever is higher), and draw a bold vertical line through the graph at that frequency.¹⁴

3] Determine the upper limit of the high band (0.8 times f_2 , or 4000 Hz, whichever is lower), and draw a bold vertical line through the graph at that frequency.¹⁵

Exercise: Make a “tolerance template:” {6.10.2}

Instructions: (Continue to use the photocopies for this exercise.)

1] The example graphs have dotted vertical lines printed at 1/3-octave frequency intervals. On each of 1/3-octave vertical graph lines in the low band, draw bold dots 4 dB higher and 4 dB lower than the frequency response curve. For example, if the level of the frequency response curve at 1000 Hz is 93 dB, place dots at the 89-dB and 97-dB levels along the 1000-Hz line.

2] Using the dots as guides, form a smooth curve that resembles the low-band portion of the frequency response curve. Do this for both the “+4 dB” and the “-4 dB” dots in the low band, up to the 2000-Hz line. (Figure \4, on page 8 of the standard, serves as an example.)

3] Similarly, for the high band, draw dots on the 1/3-octave lines at levels that 6 dB higher and lower than the frequency response curve, and connect the dots to form smooth curves that resemble the high-band portion of the frequency response curve.

The result is a “tolerance template” that can be overlaid on measured frequency responses for the same model hearing aid to check whether the measured curves meet the tolerance limits.

Exercise: **Check whether the frequency response curve meets specs**
Examples of measured frequency response curves for the hearing aids of the last exercise are given on the following page. Use your tolerance template to determine whether the measured curves meet the tolerance limits.

Instructions:

1] Make photocopies of the example measured frequency response curves.

2] Place the sheet containing the measured curve on top of the sheet containing the tolerance template and hold the sheets up to a broad light, so that the light shines through the sheets from behind.

3] Align the graph scales so that the numbers on the dB and Hz scales are aligned.

4] If necessary,, shift the measured curve up or down—without moving it left or right— for the best possible fit of the measured curve within the tolerance limits.

5] Now, if need be, shift the measured curve left of right, but not more than to cause a 10% shift in frequency relative to the specified curve.

Does the measured frequency response meet the tolerance requirements?¹⁶

If not, where are the problem spots?

What is the HFA gain of the frequency response curve (calculate the HFA output level and then subtract the input level of 60 dB)?¹⁷
Is the HFA gain of the frequency response curve precisely the reference-test gain? Why or why not?¹⁸

Measured Curves

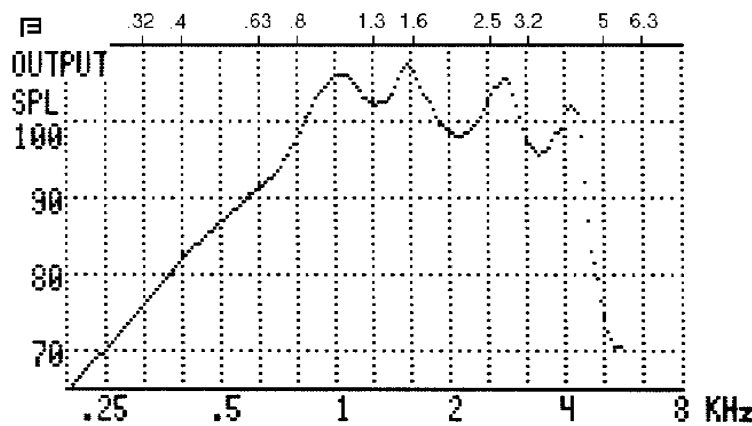
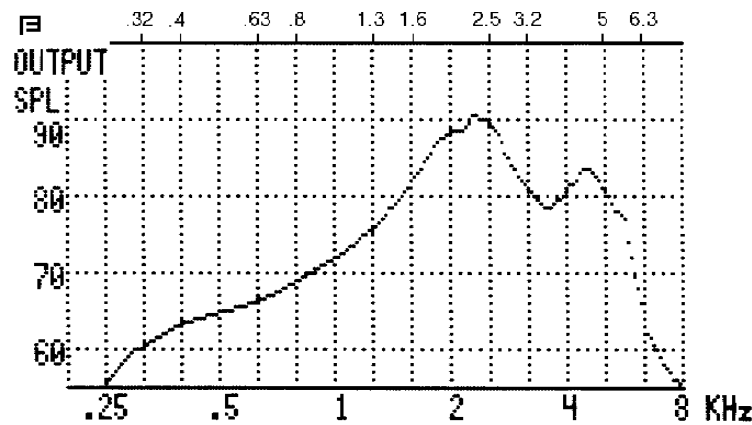

TOTAL HARMONIC DISTORTION {6.11}

Measuring percent total harmonic distortion (%THD) is normally straightforward with a hearing aid analyzer. Typically, all that is required is setting the gain control to the reference-test position, presenting the required test signals, and then reading the %THD values shown by the analyzer.

%THD test signals: For hearing aids that use the HFA frequencies for other tests, the following three test signals are used for measuring %THD:

[Lower] 500 Hz at 70 dB SPL

[Middle] 800 Hz at 70 dB SPL

[Upper] 1600 Hz at 65 dB SPL*

For special purpose hearing aids, the lower, middle, and upper test frequencies for measuring %THD are half the SPA frequencies. For example, if the SPA frequencies are 1600, 2500, and 4000 Hz, then the frequencies used to test %THD are 800, 1250, and 2000 Hz.** The SPLs remain the same: 70 dB for the lower and middle frequencies, 65 dB for the upper.

Tolerance:

The measured %THD values have to be less than or equal to the published values plus 3%

Exercise: Determine the %THD test frequencies:

Calculate the %THD test frequencies for a hearing aid with the manufacturer-specified SPA frequencies of 2000, 3150, and 5000 Hz.19

Notes:

* The reason that 65 dB SPL is used at 1600 Hz is that the output of most hearing aids at that frequency is higher than at the other test frequencies.

** Some hearing aid analyzers cannot produce all of the possible frequencies used for testing special purpose hearing aids. In such cases, the best thing to do is to use the closest available frequency.

THE 12-DB RULE

Percent THD does not have to be measured (or published) when the level of the frequency response curve rises 12 dB or more between the first and second harmonics (see definition of “harmonic” in the “Basic Definitions” section of this workbook). For example, if the level of the frequency response curve is 88 dB at 500 Hz, and is 100 dB (or higher) at 1000 Hz, then the %THD does not have to be measured at 500 Hz. The reason for the 12-dB rule is that when a hearing aid amplifies the second harmonic much more than the first harmonic, the large difference in amplification can magnify, to a disturbingly high level, what otherwise would be a moderate %THD value.

Exercise: **Use the 12-dB rule:**

For the frequency response curve illustrated on the following page, decide which frequencies must be tested for %THD. The example is from a general purpose hearing aid (using HFA frequencies for other tests).

Instructions:

1] Read the response curve level at 500 Hz. Read the level at 1000 Hz (the 2nd harmonic of 500 Hz). Is the level at 1000 Hz at least 12 dB higher than the level at 500 Hz? If not, then %THD must be measured at 500 Hz.²⁰

2] Read the response curve level at 800 Hz. Read the level at 1600 Hz (the 2nd harmonic). Is the level at 1600 Hz at least 12 dB higher than the level at 800 Hz? If not, then %THD must be measured at 800 Hz.²¹

3] Read the response curve level at 1600 Hz. Read the level at 3200 Hz (the 2nd harmonic). Is the level at 3200 Hz at least 12 dB higher than the level at 1600 Hz? If not, then %THD must be measured at 1600 Hz.²²

Notes:

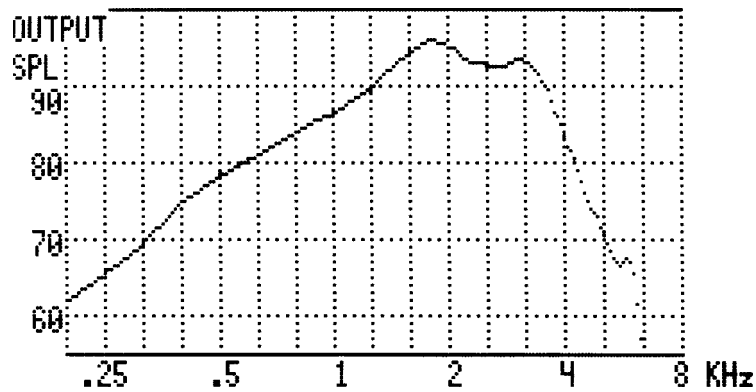

Exercise: Measure the %THD:

Use one of the AGC instruments on your list. The instrument should be a general-purpose aid, using the HFA frequencies for other tests, and should have a broad, gently sloping frequency response so that no %THD measurement is thrown out because of the 12-dB rule.

Instructions:

- 1] Prepare for testing (set the trim controls, attach the coupler, level).
- 2] Set the gain control to the reference-test position.
- 3] Set the test signal for 500 Hz at 70 dB SPL.
- 4] Read the %THD from the analyzer.
- 5] Repeat for 800 Hz at 70 dB SPL, and for 1600 Hz at 65 dB SPL.

How do the results compare with the manufacturer's specs?

Notes:

EQUIVALENT INPUT NOISE {6. 12}

The EIN figure of merit is arrived at by setting the gain control to the reference-test position, measuring the rms output level with no input signal present, and subtracting the HFA (or SPA) gain value found with a 50 dB input. The only complication is that one of the qualities of noise is that its level fluctuates continually. Consequently, when determining the rms noise output level, the measuring device must use a 0.5 second exponential averaging time constant, as stipulated in Section {4.8} of the standard. Otherwise, taking the average of several short-term samples can make a rough estimate of the ANSI EIN level.

Note: A quiet environment is critical to making a valid EIN measurement. Once the hearing aid is set up in the analyzer and ready to test, turning the aid off should result in at least a 6-dB drop in the measured noise. If not, the environment is not suitable for measuring the EIN.

Tolerance:

The EIN level has to be less than or equal to the highest value specified by the manufacturer plus 3 dB.

Exercise: *Determine the EIN level:*

Do this exercise with a general- purpose instrument (using the HFA frequencies for other tests). For this measurement, it is important to have a noise-free test environment. (Note: Because S3.22 calls for a specific averaging time constant {4.8} for noise measurements, if the analyzer is not so-equipped, the following exercise may lack some precision.)

Instructions:

- 1] Prepare for testing (set the trim controls, attach the coupler, level).*
- 2] Set the gain control to the reference-test position.*
- 3] Determine if the test environment is suitable by switching the aid off. A drop of 6 dB or more in the measured value indicates an adequately quiet testing environment.*

4] Turn the aid on again, and determine HFA gain value with a 50-dB input.

5] Turn off the test signal.

6] Record a sample of the output level. This is the noise output level of the hearing aid.

7] Repeat step [6] at least five more times. The higher the number of sample measurements, the more accurate the EIN estimate will be.

8] Calculate the average of all the noise output measurements.

9] Subtract the HFA value you found in step [4] from the average noise output level.

Notes:

BATTERY CURRENT DRAIN {6.13}

Not all hearing aid analyzers are equipped to test battery current drain. With those that are, you must use a battery simulation device that fits in the battery drawer of the aid and plugs into the analyzer. The hearing-aid manufacturer is required to state the battery type used for all the published S3.22 tests of an instrument. Settings on the analyzer let you select the battery simulation values that correspond to the battery type stated by the hearing-aid manufacturer (Annex B).

For reading the battery current, the gain control is to be set to the reference-test position and the input signal is to be 1000 Hz at 65 dB SPL.

Tolerance:

The battery current drain may not be more than 20% higher than the highest value specified by the manufacturer

Exercise: Determine the maximum permissible battery current:

Determine the maximum permissible battery current for a hearing aid whose published spec is 0.8 milliamperes (mA). (Hint: Multiply the spec figure by 1.2—this is equivalent to finding 120% of the spec figure.)²³

Notes:

Exercise: Measure the battery current:

Use the same instrument you used in the exercise for EIN.

Instructions:

- 1] Prepare for testing (set trim controls, attach the coupler, level).
- 2] Set the gain control to the reference-test position.
- 3] Attach the appropriate battery simulator and select the appropriate battery type on the analyzer.
- 4] Set the test signal for 65 dB SPL at 1000 Hz.
- 5] Record the battery current reading.

How does your reading compare with the manufacturer's spec?

Notes:

TELECOIL SENSITIVITY {6.14}

Not all hearing aid analyzers are equipped to test telecoil performance. With those that are, you must use a special signal coil—a telephone magnetic field simulator—to generate a test current such that the number of turns in the coil times the current equals 6. Such a current will generate a magnetic field that is consistent both in level and shape, as is required by the standard {3.24}. The suggested number of turns is 10. The gain control of the hearing aid is set to the reference-test position, and the hearing aid is oriented so that in the case of a BTE aid, the aid is as flat against the surface of TMFS as possible, and in the case of an ITE aid, the faceplate is parallel to the surface of the TMFS.

Three measurements are done to test the sensitivity of the telecoil.

▪ SPLITS CURVE {6.14.1}

The SPLITS Curve is a response curve measured with the hearing aid set to telecoil mode with the gain control at the reference-test position. The response must be measured at least between the frequencies of 200 and 5000 Hz.

Tolerance: None

The SPLITS Curve is supplied for information purposes only.

Exercise: Measure the SPLITS curve:

- 1] *Set the hearing aid's gain control to the reference-test position, and switch the aid to telecoil mode.*
- 2] *Before placing the aid in the TMFS field, locate the position of the aid that results in the least magnetic noise. Keep in mind that a BTE aid must rest flat against the TMFS surface and an ITE aid's faceplate must be parallel to the TMFS surface.*
- 3] *Turn on the magnetic field and measure a response curve.*

▪ **HFA- OR SPA-SPLITS {6.14.2}**

The HFA (or SPA) SPLITS measurement is an average of the SPLITS values at 1000, 1600, and 2500 Hz (or at the three special purpose frequencies specified by the manufacturer).

Tolerance:

The HFA- or SPA-SPLITS value must be within ± 6 dB of the manufacturer's spec.

Exercise: *Determine the HFA-SPLITS:*
A SPLITS curve is displayed on the accompanying graph. Calculate the HFA-SPLITS value.²⁴

Notes:

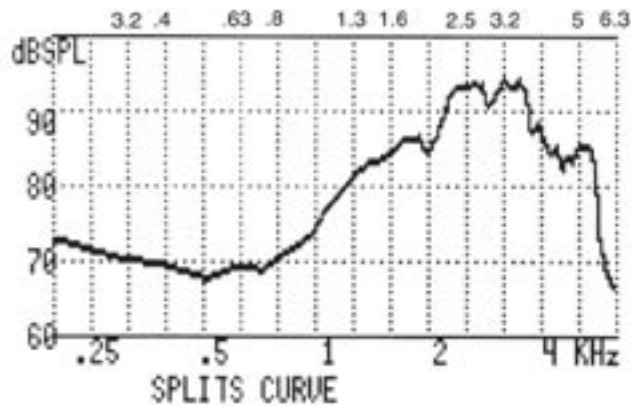

▪ **RELATIVE SIMULATED EQUIVALENT TELEPHONE SENSITIVITY {6.14.3}**

The relative simulated equivalent telephone sensitivity (RSETS) measurement compares the reference-test gain to the HFA- or SPA-SPLITS measurement. The RSETS value is stated for information purposes. It gives you an idea of how much gain control adjustment is necessary to produce similar amplification when the aid is switched between normal and telecoil modes.

Exercise: Determine the RSETS value:

Instructions:

1] Use graph 1 (hearing aid in normal mode) to calculate the reference-test gain.²⁵

2] Use graph 2 (hearing aid in telecoil mode) to calculate the HFA-SPLITS value.²⁶

3] Subtract the reference-test gain plus 60 dB from the HFA-SPLITS value. The result is the Relative Simulated Equivalent Telephone Sensitivity.²⁷

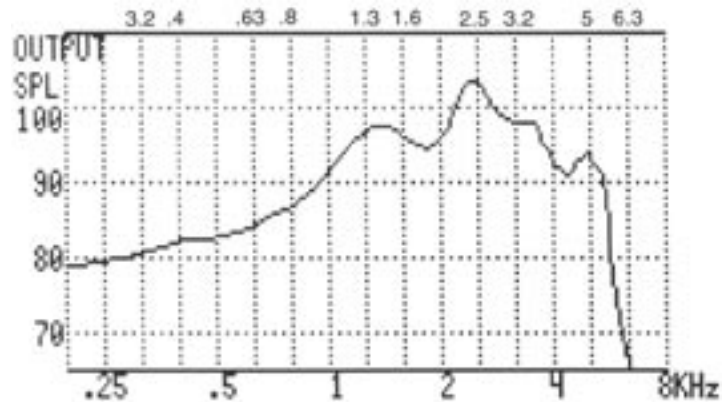

graph 1

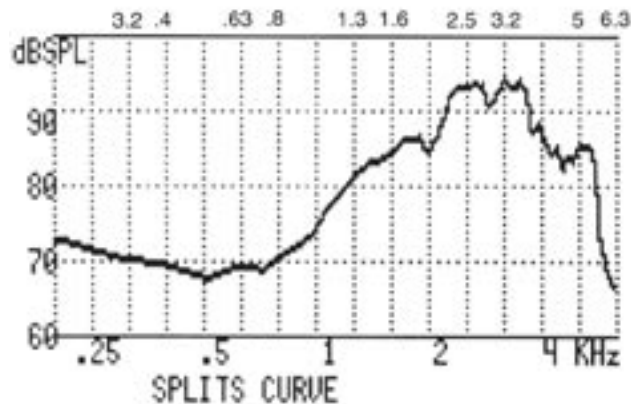

graph 2

INPUT-OUTPUT (1/0) CHARACTERISTIC (AGC instruments only) {6.15.1}

An input-output test characterizes the function of an AGC circuit. With the gain control set to the reference-test position, compression controls set to maximum, and the signal frequency set to that specified by the manufacturer (250, 500, 1000, 2000, or 4000 Hz—the manufacturer may choose to test at more than one of these frequencies), output levels are measured for input levels between 50 and 90 dB in 5 dB steps. The data are plotted on a graph having equal, linear dB scales for input (horizontal scale) and output (vertical scale). Consequently, the input-output characteristic for linear processing will result in a straight line, rising from left to right at a 45° angle. Compression (gain reduction) will result in a decreased slope.

Tolerance:

After the measured curve is adjusted up or down so that the measured and specified output levels are matched at the 70-dB-input-level point, the measured output levels for input levels of 50- and 90-dB SPL have to be within ± 5 dB of the specified values.

Exercise: Measure the I/O characteristic:

Use one of the AGC hearing aids from your list.

Instructions:

- 1] Prepare for testing (set trim controls, attach the coupler, level).
- 2] Set the gain control to the reference-test position.
- 3] Set the test signal for 50-dB SPL at one of the manufacturer specified frequencies.
- 4] Record the output level.
- 5] Repeat steps [3] and [4] adjusting the signal level up 5 dB each time until you reach 90-dB SPL.
- 6] Plot the data on a linear-by-linear graph. You may use the empty graph printed below. (Suggestion: Use a photocopy of the empty graph.)
- 7] From the manufacturer's input-output characteristic, record the specified output level for a 70-dB SPL input level. Subtract your measured value for a 70-dB SPL input from this specified value. Call the resulting value the "I/O offset factor."
- 8] Add the "I/O offset factor" to the measured output levels for input levels of 50- and 90-dB SPL.

Do the resulting values meet the tolerance?

Notes:

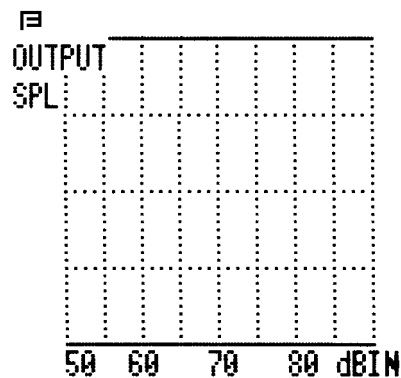

Exercise: Find the AGC knee point:

What are the specified and measured AGC knee points for the hearing aid of the last exercise? (Refer to “AGC knee point” in the “Basic Definitions” section of this workbook, and in Section {3.12} of the standard.)

**ATTACK & RELEASE TIMES
(AGC instruments only) {6.15.2}**

Attack and release times tell you how fast the output of a processing circuit changes in reaction to large fluctuations in the input level. This is a test that you cannot do manually. An automatic program or a storage oscilloscope is necessary. Not all hearing aid analyzers are equipped to test attack and release times. And as with EIN measurements, a very quiet test environment is necessary. Refer to the “Basic Definitions” section of this manual, and to Section {6.15.2} in the standard, for technical information about attack and release tests.

Tolerance:

Both the attack and the release times have to be within ± 5 milliseconds (ms) or $\pm 50\%$ (whichever is larger) of the manufacturer’s spec.

Because an automatic program or a storage oscilloscope is required for measuring attack and release times, no exercise for attack and release times is given.

TESTS FOR LINEAR INSTRUMENTS

TEST	TEST CONDITIONS
OSPL90 curve	Input level: 90 dB SPL; gain control full-on
OSPL90 max	From OSPL90 curve
OSPL90 (HFA or SPA)	From OSPL90 curve
Full-on gain (HFA or SPA)	Input level: 50 dB SPL; gain control at full-on
Reference-test gain	OSPL90 (HFA or SPA) – 77 dB, or full-on gain, whichever is lower
Frequency response curve	Input level: 60 dB SPL; gain control at reference-test position
Frequency range (f_1 and f_2)	From frequency response curve; draw line at HFA (or SPA) level – 20 dB
Percent total harmonic distortion	500 Hz (or half the low SPA freq) @ 70 dB SPL; 800 Hz (or half the mid SPA freq) @ 70 dB SPL; 1600 Hz (or half the high SPA freq) @ 65 dB SPL; gain control at reference-test position; 12 dB-rule applies
Equivalent input noise (EIN) level	Very quiet ambient conditions; input signal off; gain control at reference-test position; subtract HFA gain value found with a 50-dB-SPL input signal from the rms output
Battery current drain	Input level: 65 dB SPL @ 1000 Hz; gain control at reference-test position
SPLITS curve	Magnetic field of 6 milliamperes divided by number of coils; gain control at reference-test position; hearing aid in telecoil mode
HFA- or SPA-SPLITS	HFA or SPA value found using decibel values on SPLITS curve
Relative Simulated Equivalent Telephone	Subtract HFA (or SPA) found with aid in
Sensitivity (RSETS)	normal mode with gain control at reference-test position and input signal of 60 dB SPL from the HFA- or SPL-SPLITS value

TESTS FOR AGC INSTRUMENTS

TEST	TEST CONDITIONS
OSPL90 curve	Input level: 90 dB SPL; gain control full-on; compression controls set to minimum
OSPL90 max	From OSPL90 curve
OSPL90 (HFA or SPA)	From OSPL90 curve
Full-on gain (HFA or SPA)	Input level: 50 dB SPL; gain control full-on; compression controls set to minimum
Reference-test gain	OSPL90 (HFA or SPA) – 77 dB, or full-on gain, whichever is lower; compression controls set to minimum
Frequency response curve	Input level: 60 dB SPL; gain control at reference test position; compression controls set to minimum
Frequency range (f_1 and f_2)	From frequency response curve; use line at HFA (or SPA) level – 20 dB
Percent total harmonic distortion	500 Hz (or half the low SPA freq) @ 70 dB SPL; 800 Hz (or half the mid SPA freq) @ 70 dB SPL; 1600 Hz (or half the high SPA freq) @ 65 dB SPL; gain control at reference-test position; compression controls set to minimum; 12 dB-rule applies
Input-output (I/O) characteristic	Input frequency of 250, 500, 1000, 2000, or 4000 Hz or any combination of those frequencies; input level varies from 50 to 90 dB SPL in 5-dB steps; gain control in reference-test position; compression controls set to maximum
Attack time	Input frequency of 250, 500, 1000, 2000, or 4000 Hz or any combination of those frequencies; input level switched abruptly from 55 to 90 dB SPL; compression controls set to maximum
Release time	Input frequency of 250, 500, 1000, 2000, or 4000 Hz or any combination of those frequencies; input level switched abruptly from 90 to 55 dB SPL; compression controls set to maximum

Equivalent input noise (EIN) level	Very quiet ambient conditions; input signal off; gain control at reference-test position; subtract HFA gain value found with a 50-dB-SPL input signal from the rms output; compression controls set to minimum
Battery current drain	Input level: 65 dB SPL @ 1000 Hz; gain control at reference-test position; compression controls set to minimum
SPLITS curve	Magnetic field of 6 milliamperes divided by number of coils; gain control at reference-test position; compression controls set to minimum; hearing aid in telecoil mode
HFA- or SPA-SPLITS	HFA or SPA value found using decibel values on SPLITS curve
Relative Simulated Equivalent Telephone Sensitivity (RSETS)	Subtract HFA (or SPA) found with aid in normal mode with gain control at reference-test position and input signal of 60 dB SPL from the HFA- or SPA-SPLITS value

Exercise: Run a “complete” ANSI test sequence:

Using three of the linear instruments on your list, run all the tests for linear instruments, one at a time, as listed in the table given earlier. Compare the results to the published specifications. (Don’t forget to set the aid controls for highest gain and output and broadest frequency range.) Do the results meet all tolerances? If not, list the test which do not meet specs.

Exercise: Run a “complete” ANSI test sequence:

*Using three of the AGC instruments on your list, run all the tests for AGC instruments, one at a time, as listed in the table given earlier. * Compare the results to the published specifications. (Don’t forget to set the aid controls for highest gain and broadest frequency response. Set the AGC controls as the manufacturer specifies.) Do the results meet all tolerances? If not, list the tests that do not meet specs.*

*Omit attack and release tests.

SUMMARY OF TOLERANCES

The tolerances of the measurement equipment must be added to or subtracted from S3.22 tolerances, as appropriate. (Refer to Section {6.16} for further explanation).

TEST	TOLERANCE
OSPL90 max	Specified value + 3 dB
OSPL90 (HFA or SPA)	Specified value ± 4 dB
Full-on gain (HFA or SPA)	Specified value ± 5 dB
Reference-test gain	None (information purposes only)
Reference-test position	Gain control must be within ± 1.5 dB of the target setting, such that the JFA (or SPA) output for a 6—dB-SPL: input is 17 dB below the OSPL90 HFA (or SPA), unless the full-on gain is already lower
Frequency response curve	Low band: specified curve ± 4 dB; high band: specified curve ± 6 dB; curve may be shifted 10% left or right, and unlimited up or down
Frequency range	None (information purposes only)
Percent total harmonic distortion	Max is specified value + 3%
Equivalent input noise (EIN) level	Max is highest specified value + 3 dB
Battery current drain	Max is highest specified value + 20%
Input-output (I/O) characteristic	After normalizing at 70-dB-SPL input point, outputs for 50- and 90-dB-SPL inputs must be within ± 5 dB or specified values.
Attack and release times	Specified value ± 5 ms or $\pm 50\%$, whichever is larger
HFA- or SPA-SPLITS	Within ± 6 dB of specified value
Simulated Telephone Sensitivity	None (for informational purposes only)

ANSWERS

1. An example of where most (if not all) clinical hearing aid analyzers fall short of ANSI requirements is that an anechoic environment is required for generating “an essentially spherical sound field” for the purpose of testing directional hearing aids {4.3}. The accuracy of all measurements on directional instruments can be affected by not meeting this requirement.
2. Should be within ± 1.5 dB between 200 and 2000 Hz, and within ± 2.5 dB between 2000 and 5000 Hz.
3. 129
4. 43
5. $(87.5 + 88 + 97.5 = 273) \div 3 = 91$
6. $(78.5 + 88 + 77 = 243.5) \div 3 = 81.2$
7. $[(112.5 + 109 + 114 = 335.5) \div 3 = 111.8] - 77 = 34.8$
8. 99.6 dB SPL (“99.5 dB” is an incomplete answer. You must give the full “dB SPL” designation, because you are expressing an amplified sound pressure level.)
9. $[(107 + 107 + 110 = 324) \div 3 = 108] - 17 = 91$
10. A: 81 dB SPL; B: 106 dB SPL
11. A: 61 dB SPL; B: 86 dB SPL
12. A: f_1 320 Hz, $f_2 \approx 7000$ Hz; B: $f_1 \approx 450$ Hz, $f_2 \approx 4800$ Hz
13. A: 320 - 5000 Hz; B: 450 - 4800 Hz
14. A: 1.25×320 Hz = 400 Hz; B: 1.25×460 Hz = 562.5 Hz
15. A: 4000 Hz; B: 0.8×4800 Hz = 3840 Hz
16. Although both measured curves show variability with respect to the published spec, both are within the allowed tolerances.

17. A: $(72 + 82 + 89.5 = 81.2) - 60 = 21.2$;
B: $(106 + 108 + 102.5 = 105.5) - 60 = 85.5$
18. At best, the response-curve gain need only be within ± 1.5 dB of the specified reference test gain. But the difference could be even greater: Recall that there is no tolerance on the reference test gain, and the frequency response curve may be shifted up or down to an unlimited degree.
19. The SPA frequencies $\times 1/2$: 1000, 1575, and 2500 Hz
20. No, 8 dB
21. No, 10.5 dB
22. No, 1.5 dB
23. $1.2 \times 0.8 \text{ mA} + 0.96 \text{ mA}$
24. 83.7 dB
25. OSPL90-HFA $-77 = 20$ dB
26. 83.7 dB
27. $83.7 - (20 + 60) + 3.7$